

## DESIGN OF A STATE OBSERVER USING DECAY RATE LMI CONSTRAINTS FOR FAULT DETECTION IN MECHANICAL SYSTEMS

*PROJETO DE OBSERVADOR DO ESTADO USANDO RESTRIÇÕES LMI DE TAXA DE DECAIMENTO PARA DETECÇÃO DE FALHAS EM SISTEMAS MECÂNICOS*

**Edson Hideki Koroishi<sup>1</sup>, Gilberto Pechoto de Melo<sup>2</sup> e Edvaldo Assunção<sup>3</sup>**

<sup>1,2</sup>UNESP – Universidade Estadual Paulista, Avenida Brasil Centro, CEP 15385-000, Ilha Solteira, SP Brasil  
E-mail: <sup>1</sup>edson.koroishi@gmail.com, <sup>2</sup>gilberto@dem.feis.unesp.br

<sup>3</sup>UNESP – Universidade Estadual Paulista, Avenida Brasil Centro, nº 56 CEP 15385-000. Ilha Solteira, SP Brasil  
Departamento de Engenharia Mecânica, E-mail: <sup>3</sup>edvaldo@dee.feis.unesp.br

### ABSTRACT

Nowadays, one of the most important concerns for many companies is to maintain the operation of their systems without sudden equipment break down. Because of this, new techniques for fault detection and location in mechanical systems subject to dynamic loads have been developed. This paper studies of the influence of the decay rate in the design of state observers using LMI for fault detection in mechanical systems. This influence is analyzed by the performance index proposed by Huh and Stein for the condition of a state observer. An example is presented to illustrate the methodology discussed.

**Keywords:** State observers, Decay rate, Performance index, Faults detection, LMI.

### RESUMO

Hoje em dia, uma das mais importantes preocupações para muitas empresas é manter o funcionamento dos seus sistemas sem interrupções. Devido a isso, novas técnicas de detecção de falhas e localização em sistemas mecânicos sujeitos a cargas dinâmicas têm sido desenvolvidas. Este artigo estuda a influência da taxa de decaimento no projeto de observadores de estado usando LMI para detecção de falhas em sistemas mecânicos. Essa influência é analisada pelo índice de desempenho proposto por Huh e Stein para a condição de um observador de estado. Um exemplo é apresentado para ilustrar a metodologia discutida.

**Palavras-chave:** Observador de estado, Taxa de decaimento, Índice de desempenho, Detecção de falhas, LMI.

### 1 – INTRODUCTION

Nowadays, one of the concerns of many companies is to maintain the operation of their systems without sudden and unplanned stoppages. Because of this, new techniques for fault detection and location in mechanical systems submitted to dynamic loads have been developed.

Since the introduction of the state observer by Luenberger (1964), many methodologies have been proposed for condition monitoring of the machines using this technique (GE and FANG, 1987; ELMAS and DE LA PARRA, 1996). However, state observers have been used mainly to solve control problems and to detect possible faults in sensors and instruments (CLARK, 1978; WATANABE and HIMMELBLAU, 1982). Moreover, much work has been theoretical, with little experimental verification (PARK, SHIN and CHUNG, 2001; TRINH and ALDEEN, 1998; FRANK and SELIGER, 1991).

The main focus of the following literature review is the detection and location of mechanical system faults. Theories which are related to state observers, fault detection and state observers using LMI have been taken into account. State-of-the-art theories are presented in chronological order, with the most significant works being selected.

Luenberger (1964) states that the major part of the theory of modern control is based on the assumption that the state vector of the system to be controlled is available for direct measurement. However, in many practical situations, only a few states are available. The author shows how the inputs and outputs that are available can be used to build an estimate observer, or just an observer. This work describes the fundamental theory of the state observer.

Luenberger (1966) proposed that for a linear system, its state vector can be approximately reconstructed by means of a designed observer. The “n” order state vector with “m” independent outputs can be reconstructed, building the remaining states from differential conditions. He also proved that the design of an observer with “m” outputs can be reduced to an “m” order observer as if they were simple output subsystems simplifying the complexity of the observer.

Luenberger (1971) used a methodology for reconstructing states using state observers and discussed topics about identity and reduced order observers.

Clark (1978) introduced the concept of the robust observer, designing state estimation filters for instruments default detection, robust enough to withstand the uncertainties. The base for the filters was the separation of the effects of faults from the uncertainties.

Watanabe and Himmelbleau (1982) presented a method to detect faults in instruments in nonlinear time dependent processes, including uncertainties such as modeling errors, parameter ambiguity and input and output noise. The main goal of their work was the development of state estimator filters with minimum sensitivity to uncertainties and maximum sensitivity to instrument faults.

Ge and Fang (1987) described a novel concept for the detection of components under failure by robust observation, considering a mathematical model corresponding to “m” components coupled by non-estimated states. They determined the design of devices to monitor the operation of “n” components and fault detection. In the case of an observable system, some first order components can be monitored for the purpose of diagnosis without information of possible faults modes. Due to the observer robustness, the authors analyzed some reactions such as linearization and measurement errors, noise presence, numerical errors, etc.

Huh and Stein (1994) proposed a simple performance index to quantify the condition of the state observers. This index is the condition number of an eigenvector matrix in terms of the L2 norm.

Choy, Liang and Xu (1995) described a methodology based on vibration theory which could be used for the detection of faults in systems modeled by finite elements using beam elements supported by an elastic foundation.

Faitakis, Tthapliyal and Kantor (1998) proposed a new approach for selecting alarm thresholds in a simple fault detection system. Bounds were computed on the magnitudes of the minimum detectable fault and the maximum non-detectable fault. The use of the norm for this calculation results in a linear matrix inequality (LMI) problem. An example was presented and a filter design was proposed that enhances the ability to distinguish between a fault and a disturbance.

Mohiuddin and Khulief (1999) described, using finite elements, the dynamic model of a rotor-bearing system, considering the gyroscopic effect and the combination between the deformations of torsion and bending. They carried out a modal transformation using complex models and then, obtained a model of reduced order, which was validated numerically.

Valer (1999) established control systems design using state observers. Also, he revised the principal types of observers, and used modern techniques of robust control to improve the robustness properties of the control system.

Bara *et al.* (2001) investigated the design of a parameter-dependent state observer that allows the estimation of the state of an affine linear parameter-varying (LPV) system. The observer has the property to be parameter-dependent since the corresponding state space matrices are scheduled using an interpolation method. Moreover, the stability of the estimation error is based on the existence of an affine parameter-dependent Lyapunov function. The main contribution of this paper is that the problem of the observer design and the existence of such a Lyapunov function are interpreted as a flexible LMI feasibility condition.

Jiang and Li (2004) focused on the problem of robust stabilization for a class of linear systems with uncertain parameters and time varying delays in states, using LMI to determine the gain of the state observers and controllers.

Lemos and Melo (2004) presented state observer methodology for detection and location of faults in rotary systems, taking into account their foundations. According to them, state observer methodology is able to reconstruct non-measured states or estimated values arising from difficult access locations in the system. In fact, those faults can be detected without the need for a direct measurement.

Morais *et al.* (2005) used the Kalman filter as a stochastic state observer for the detection of faults in mechanical systems in the presence of aleatoric noises and non linear inputs.

Yaz, Jeong and Yaz (2006) addressed the important problem of stochastic resilience of a discrete-time Luenberger observer, which is the maintenance of convergence and/or performance when the observer is erroneously implemented. A common LMI framework was presented to address the stochastic resilient design problem for various performance criteria in the implementation based on the knowledge of an upper bound on the variance of the random error in the observer gain.

Jiang and Tang (2006) proposed a new approach for the synchronization of complex dynamical networks based on a state observer design. Some conditions for synchronization, in the form of an inequality, were established based on the Lyapunov stability theory

Fernandes, Koroishi and Melo (2007) used state observers for diagnosis of faults in mechanical systems with dynamic vibration absorbers (DVAs).

Abbaszadeh and Marquez (2008) proposed a new approach for the design of robust H observers for a class of Lipchitz nonlinear systems with time-varying uncertainties based on LMI.

Park, Jung and Park (2008) studied the design problem of a state estimator for a class of discrete-time neural networks. A delay-independent LMI criterion for the existence of the estimator is derived by using the Lyapunov method.

Fault detection technique employing state observers can reconstruct non measured states or values of difficult access locations. In this case, faults can be detected and monitored without measurements. The technique consists of the development of a system model and comparing the estimated output with the measured output. The main aim of this work is to study the influence of the decay rate in obtaining well-conditioned state observers for fault detection in mechanical systems. These observer designs are described using LMI. For analysis of this influence, the performance index proposed by Huh and Stein (1994) was used to obtain a well-conditioned state observer.

## 2 – STATE OBSERVER FORMULATION

Consider a linear time invariant system described by:

$$\{\dot{x}(t)\} = [A]\{x(t)\} + [B]\{u(t)\} \quad (1a)$$

$$\{y(t)\} = [C_{me}] \{x(t)\} + [D] \{u(t)\} \quad (1b)$$

where:

$[A] \in R^{n \times n}$  is the dynamical matrix;

$[B] \in R^{n \times p}$  is the input matrix;

$[C_{me}] \in R^{k \times n}$  is the measurement matrix;

$[D] \in R^{k \times p}$  is the matrix of direct inputs;

$n$  is the order of the system,  $p$  the number of inputs  $\{u(t)\}$ ,  $k$  the number of outputs  $\{y(t)\}$ .

One of the advantages of this type of representation is that the state vector  $\{x(t)\}$  contains enough information to completely describe the latest behavior of the system, and the future behavior is governed by a simple first order differential equation.

A state observer for the system described by Eq. (1) is defined by:

$$\{\dot{\bar{x}}(t)\} = [A] \{\bar{x}(t)\} + [B] \{u(t)\} + [L] (\{y(t)\} - \{\bar{y}(t)\}) \quad (2a)$$

$$\{\bar{y}(t)\} = [C_{me}] \{\bar{x}(t)\} \quad (2b)$$

where:

$[L]$  is the observer matrix;

$\{\bar{y}(t)\}$  is the output of the observer;

$\{\bar{x}(t)\}$  is the state vector of the observer;

The estimation error of the state is:

$$\{e(t)\} = \{\bar{x}(t)\} - \{x(t)\} \quad (3)$$

and the estimation error on the output (residue) is given by:

$$\{\varepsilon(t)\} = \{\bar{y}(t)\} - \{y(t)\} \quad (4)$$

### 2.1 State Observer Methodology

Many control systems are based on the supposition that the full state vector is available for direct measurement, but in practice, all the variables are not always available, and the variables that are unavailable for direct measurement must be estimated.

Therefore, control systems using state observers can reconstruct the non-measured states or estimate the values of difficult access points in the system. However, the necessary condition for this reconstruction is that all the states should be observable (LUENBERGER, 1964; D'AZZO and HOUPIS, 1988).

Figure (1) shows a logical diagram for faults detection and location in mechanical systems using the state observer technique.

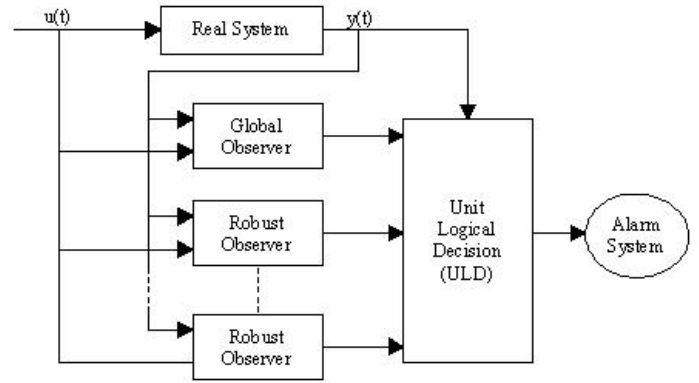

Figure 1 – Observation System.

In the system shown in Figure (1), when a certain component begins to fail, the state observer is capable of quickly detecting the influence of this fault, because the observer is quite sensitive to any incipient irregularity that appears in the system. The state observer is a group of ordinary first-order differential equations that represents the same response as that of the real system, when it is working properly. Therefore, the idea is to use this effect for the state observer to detect and locate possible faults in a mechanical system.

In this set of observers, the role of the global observer is to verify if the system is working properly, without any indications of faults, because this observer uses the same system matrix of the mechanical system analysis. Thus, the global observer can detect a possible system fault or irregularity in the analysis if the system's response is not coincident with the global observer's response.

If a possible fault is detected, the next step would be to locate such fault, and that is why robust observers are used. The robust observers are projected by partly removing the parameters subject to faults in their dynamic matrix.

Therefore, the robust observer response that approaches the response of the faulty system will be the observer responsible for the location of this possible system fault.

There are still possibilities for one or more parameters to fail at the same time. In this case, the solution would be to design robust state observers to all parameters subject to failures.

Finally, it is the Unit of Logical Decision (ULD) that collects and analyzes the difference between the real system and the designed state observers, in order to detect and locate faults or irregularities in the system. This unit also analyzes the progression of possible system faults, and activates, when necessary, an alarm system. This alarm system can be ready to be activated when a determined variation occurs in a certain parameter.

### 2.2 Performance Index

According to Huh and Stein (1994) an ill-conditioned state observer means that the transient performance and permanent regime of the observer can become more sensitive at ill conditioning factors such as an unknown initial estimation, unknown change in the monitoring

machine and errors in the instrumentation and sensors (Huh and Stein, 1994).

An ill-conditioned state observer works well when the conditions are exactly equal as those assumed initially (for example without bias errors, and perfect model), but works more precariously when these conditions do not occur. Huh and Stein (1995), Huh, Jung and Hong (2003) quantitatively investigated the transient and the stationary state input of the observer by considering the error due to ill conditioning factors.

Huh and Stein (1994) proposed a simple performance index to quantify the condition of the state observers. This index is the condition number of eigenvector's matrix in terms of the  $L_2$  norm.

$$k_2(P) = \|P\|_2 \|P^{-1}\|_2 \quad (5)$$

where P is the eigenvector matrix of state observer.

### 3 – LINEAR MATRIX INEQUALITIES

The history of LMI in the analysis of dynamical systems goes back more than 100 years to 1890, when Aleksandr Mikhailovich Lyapunov presented his work, introducing the Lyapunov Theory (Boyd *et al.*, 1994). He showed that the differential equation:

$$\dot{x}(t) = Ax(t) \quad (6)$$

is stable (all the trajectories converge to zero), if and only if there is a positive-definite matrix P such that:

$$A^T P + PA > 0 \quad (7)$$

The inequality in Eq. (7) is known as the Lyapunov inequality.

Currently, LMI have been the object of study by many researchers: control of continuous and discrete systems in time (GHAOUI and NICULESCU, 2000), optimal control and robust control (VAN ANTWERP, and BRAATZ, 2000; SILVA and LOPES, 2004), model reductions (Assunção, 2000), control of nonlinear systems, theory of robust filters (Palhares, 1998), system identification, control with variable structures (TEIXEIRA, PIETROBOM and ASSUNÇÃO, 2000), control using Fuzzy model (TEIXEIRA, LORDELO and ASSUNÇÃO, 2000), detection, location and quantification of faults (ABDALLA, ZIMMERMAN and GRIGORIADIS, 1999; ABDALLA, ZIMMERMAN and GRIGORIADIS, 2000; WANG and LAM, 2007).

#### 3.1 Linear Differential Equation

A Linear Differential Equation (LDI) is defined by (Boyd *et al.*, 1994):

$$\dot{x} \in \Omega x, \quad x(0) = x_0 \quad (8)$$

where  $\Omega$  is a subset of  $R^{n \times n}$ . The LDI given by Eq. (8) can be interpreted as a set of linear time-varying systems. Every trajectory of the LDI satisfies:

$$\dot{x} = A(t)x, \quad x(0) = x_0 \quad (9)$$

for some  $A: R_+ \rightarrow \Omega$ , for any  $A: R_+ \rightarrow \Omega$ , the solution of Eq. (9) is a trajectory of the LDI given by Eq. (8). In control theory, the LDI, given by Eq. (8) could be described as an “uncertain time-varying linear system”, with the set  $\Omega$  describing the “uncertainty” in the matrix  $A(t)$ .

A generalization of LDI can be obtained for linear systems with inputs and outputs (Boyd *et al.*, 1994). Consider the following system:

$$\begin{aligned} \dot{x} &= A(t)x + B_u(t)u + B_w(t)w, & x(0) &= x_0 \\ z &= C_z(t)x + B_{zu}(t)u + B_{zw}(t)w \end{aligned} \quad (10)$$

where  $x: R_+ \rightarrow R^n$ ,  $u: R_+ \rightarrow R^{n_u}$ ,  $w: R_+ \rightarrow R^{n_w}$ ,  $z: R_+ \rightarrow R^{n_z}$ .  $x$  is the state,  $u$  is the input,  $w$  is the disturbance and  $z$  is the output.

The matrix in Eq. (10) satisfies:

$$\begin{bmatrix} A(t) & B_u(t) & B_w(t) \\ C_z(t) & B_{zu}(t) & B_{zw}(t) \end{bmatrix} \in \Omega \quad (11)$$

for all  $t \geq 0$  and  $\Omega \subseteq R^{(n+n_z) \times (n+n_u+n_w)}$ . In some applications one or more integers  $n_u, n_w$  or  $n_z$  can be zeros, which means the corresponding variable is not used.

#### 3.2 Decay Rate

The decay rate, known as the largest Lyapunov exponent, is defined to be the largest  $\alpha$ ,  $\alpha > 0$ , such that (Boyd *et al.*, 1994):

$$\lim_{t \rightarrow \infty} e^{\alpha t} \|x(t)\| = 0 \quad (12)$$

for all trajectories  $x$ . For stability to occur, a positive decay is necessary.

A quadratic Lyapunov function can be used to establish a lower bound for the decay rate of the LDI, given by Eq. (10). If:

$$\frac{dV(x)}{dt} \leq -2\alpha V(x) \quad (13)$$

for every trajectory, then:

$$V(x(t)) \leq V(x(0))e^{-\alpha t} \quad (14)$$

which means that for every trajectory the decay rate of the LDI (Eq. (10)) is at least  $\alpha$ .

The condition given by Eq. (13) is:

$$A^T P + PA + 2\alpha P \leq 0 \quad (15)$$

The resolution of Eq. (15) consists in solving the following generalized eigenvalue problem in  $P$  and  $\alpha$ :

$$\begin{aligned} &\text{minimize } \alpha \\ &\text{subject to } \begin{cases} A^T P + PA + 2\alpha P \leq 0 \\ P > 0 \end{cases} \end{aligned} \quad (16)$$

The optimal value of the GEPV given by Eq. (16) is the decay rate of SLIT.

The decay rate is a parameter used in the control theory, which is one of the constraints in the design. For example, Silva and Lopes (2004) used the decay rate as a constraint of design in his work, where he presented a methodology for active vibration control with robust requirements.

### 3.3 State Observer by LMI

In this case, the study of stability of the state observer is attained by using the following LMI:

$$\begin{aligned} &P(A - LC_{me}) + (A - LC_{me})^T P < 0 \\ &P > 0 \end{aligned} \quad (17)$$

where  $P=P^T$ . It is necessary to perform some manipulations of Eq. (17). After these manipulations one can get:

$$PA - PLC_{me} + A^T P - C_{me}^T L^T P < 0 \quad (18)$$

Multiplying both sides of Eq. (19) by  $P^{-1}$ , the following is obtained:

$$AP^{-1} - LC_{me}P^{-1} + P^{-1}A^T - P^{-1}C_{me}^T L^T < 0 \quad (19)$$

Letting  $X=P^{-1}$  and  $G=P^{-1}L=XL$ , one arrives at:

$$\begin{aligned} &AX + XA^T - GC_{me} - C_{me}^T G^T < 0 \\ &X > 0 \end{aligned} \quad (20)$$

where  $X=X^T$ . Note that  $P^{-1}$  exists, because  $P>0$ . In other words every eigenvalue of  $P$  is different from zero.

Considering the decay rate:

$$\begin{aligned} &AX + XA^T - GC_{me} - C_{me}^T G^T + 2\alpha X < 0 \\ &X > 0 \end{aligned} \quad (21)$$

The gain of state observer is given by:

$$L = X^{-1}G \quad (22)$$

## 4 – EXPERIMENTAL RESULTS

To verify the effectiveness of the methodology of fault detection and location in the mechanical system, considering the influence of the decay rate, a mechanical system of 3 degree of freedom was used. This is composed by 3 platforms. Figure (2) illustrates the system.

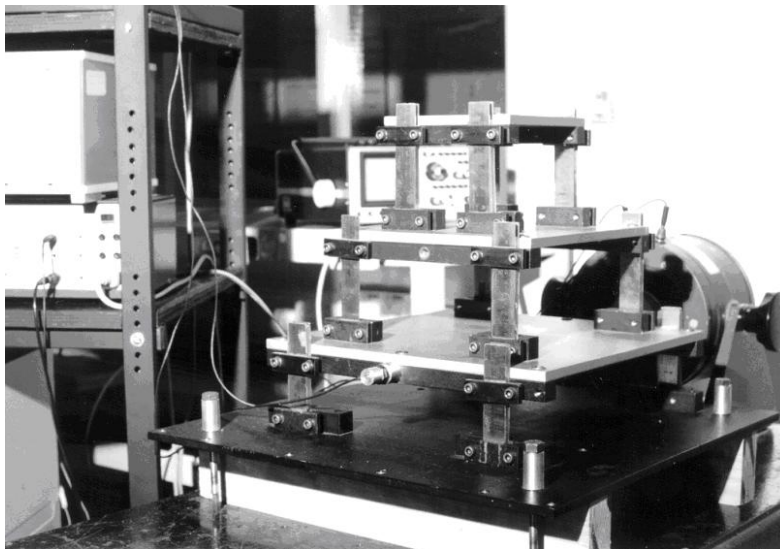

Figure 2 – Mechanical System of 3 dof (degrees of freedom).

The system presented by Figure (2) is composed of:

- 3 aluminum plates of dimensions (0.350x 0.350x 0.010)m, (0.255 x 0.255x 0.010)m and (0.158 x 0.158 x 0.010)m;
- 28 stainless steel metallic blades;
- Inferior board: 8 blades (0.420 x 0.250 x 0.001)m;
- Intermediary board: 10 blades of (0.678 x 0.250 x 0.001)m;
- Higher board: 10 blades of (0.682 x 0.250 x 0.001)m;
- 10 rubber pastilles of 0.006m thickness in the dimensions of the blades;
- Screws, steel plates for lateral and base support.

The following equipments were used:

- Conditioning of signals;
- Data Acquisition system DaqBook/DaqBoard with DasyLab software;
- Functions generator of (electronic digital laboratory) POL-32;
- Signal Amplifier;
- Electromagnetic exciting;
- Accelerometers ICP(99.0 mV/g);
- Accelerometers ICP(97.8 mV/g);
- Power Transducer (31.6 pC/N);
- Computer link cables.

For data acquisition the acquisition data DaqBook/DaqBoard (16 channels) with DasyLab software was used.

A model of the system shown in Figure (2) is given in Figure (3).

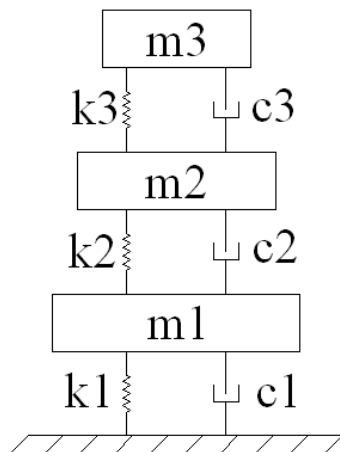

Figure 3 – Model of the mechanical system.

The numerical values of the physics parameters of the vibration table without faults are shown in Table (1).

Table 1 – Physics parameters of the vibration table.

Mass (kg)	Stiffness (N/m)	Damper (N.s/m)
$m_1 = 6,64$	$k_1 = 100065,90$	$c_1 = 18,76$
$m_2 = 4,62$	$k_2 = 84144,18$	$c_2 = 12,80$
$m_3 = 1,89$	$k_3 = 125509,60$	$c_3 = 14,17$

The faults are simulated by removing some blades. The removal of one or two blades of the board  $m_1$  represents a damage of 12.5% and 25% of stiffness of  $k_1$ . For the boards  $m_2$  and  $m_3$ , the removal of one or two blades represents damage of 10% and 20% of stiffness of  $k_2$  and  $k_3$ .

Firstly, the relation between the performance index and the decay rate was studied. For a better view of the results, in Figures (4) and (5), the inverse of the performance index was plotted, given that, a well-conditioned observer shows small values of performance index. Therefore, when the inverse of the performance index was plotted, the peaks of the graphic represent the smallest performance index. Figure (4) shows plots of the global and robust observers.

In spite of knowing that the higher the decay rate is, the lower the estimation time of the state observers will be, one can observe that a higher value of decay rate results in an ill-conditioned observer.

Figure (4) show that the smallest performance indices occur for lower values of decay rate. As can be seen in Figure (4), the smallest performance indices occur for decay rates with values lower than 50. Accordingly, Figure (5), shows the inverse of the performance indexes for the decay rate with values lower than 50.

The results, illustrated by Figure (5), reveal the performance index lower values occur for values of decay rates smaller than 10. Correspondingly, Table (2) shows the performance index for decay rate values between 4 and 9.

Examining the results in Table (2), one can see that the lower performance index for each state observer occurred for different values of decay rate. Thus, for the global observer, the decay rate is 6. And for the robust observers 87.5%  $k_1$  (It means that the faults is 12.5% of  $k_1$ ), 90%  $k_2$  (It means that the faults is 10% of  $k_2$ ), 90%  $k_3$ , 75%  $k_1$ , 80%  $k_2$  and 80%  $k_3$ , the decay rates are, respectively 6, 8, 8, 4, 7 and 9. Using these decay rates, they were developed in accordance with the state observer, and used for fault detection and location in 3 mechanical systems.

The fault considered in the system was simulated by removing a blade from table 3, which represents a damage of 10% of stiffness  $k_3$ .

Figure (6) shows the response of the real system without fault and the global observer.

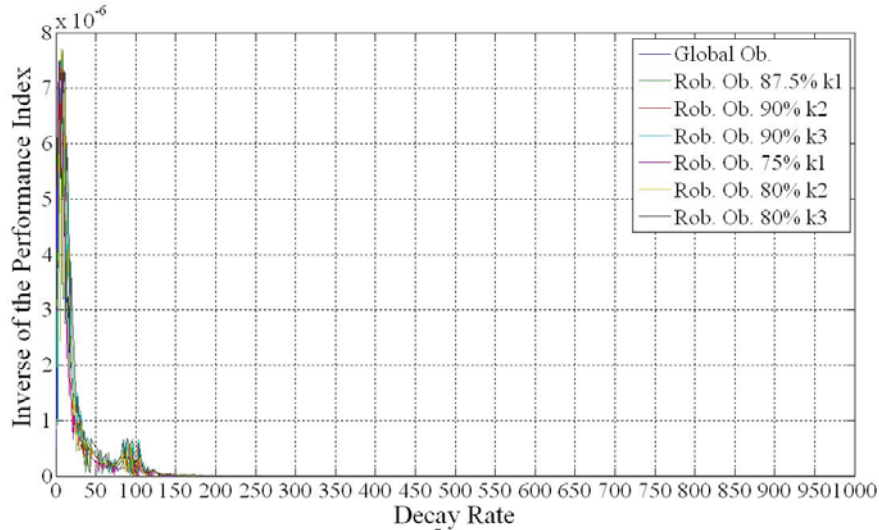

Figure 4 – Inverse of the performance index versus decay rate.

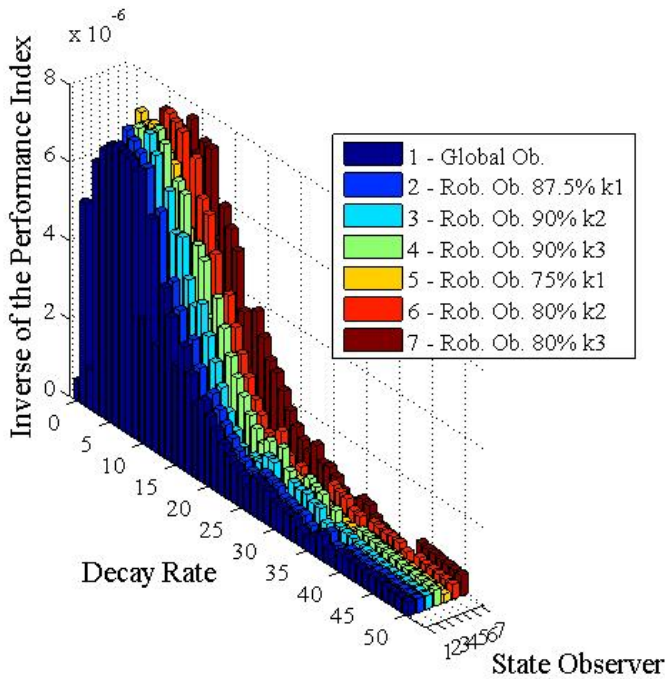

Figure 5 – Inverse of the performance index versus decay rate for the global and robust observers.

Table 2 – Performance index of state observers for decay rate values between 4 and 9.

Decay Rate	4	5	6	7	8	9
<b>Global Observer</b>	1.4549e+05	1.4099e+05	<b>1.3894e+05</b>	1.4046e+05	1.4178e+05	1.4552e+05
<b>Rob. 87.5% k1</b>	1.7019e+05	1.4652e+05	<b>1.3308e+05</b>	1.3605e+05	1.4001e+05	1.4541e+05
<b>Rob. 90% k2</b>	1.6229e+05	1.4039e+05	1.5279e+05	1.9395e+05	<b>1.3246e+05</b>	1.4063e+05
<b>Rob. 90% k3</b>	1.5538e+05	1.3718e+05	1.4853e+05	1.4010e+05	<b>1.3212e+05</b>	1.3681e+05
<b>Rob. 75% k1</b>	<b>1.3335e+05</b>	1.3718e+05	1.3518e+05	1.3638e+05	1.4532e+05	1.4922e+05
<b>Rob. 80% k2</b>	1.5941e+05	1.4120e+05	4.1278e+05	<b>1.2974e+05</b>	1.3182e+05	1.3429e+05
<b>Rob. 80% k3</b>	1.4809e+05	1.3399e+05	1.8575e+05	1.3739e+05	2.8891e+05	<b>1.3003e+05</b>

In Figure (5) one can observe that the global observer is compatible with the system, since the responses were coincident. This demonstrated the validity of the global observer

Figure (6) represents the response of the real system with fault and the global observer. In this graph, the presence of a fault in the system can be observed, since the graphs of the responses were not coincident. From the graph of the defective real system, whose parameter to be determined was modified to result in such fault, constructing a robust observer for each parameter is subject to failing.

Analyzing the others graphics of Figures (6) and (7), one can see that only displacement of the mass  $m_1$  of the real system with fault and the robust observer  $90\% k_3$  are equal. Therefore, the fault is detected and located.

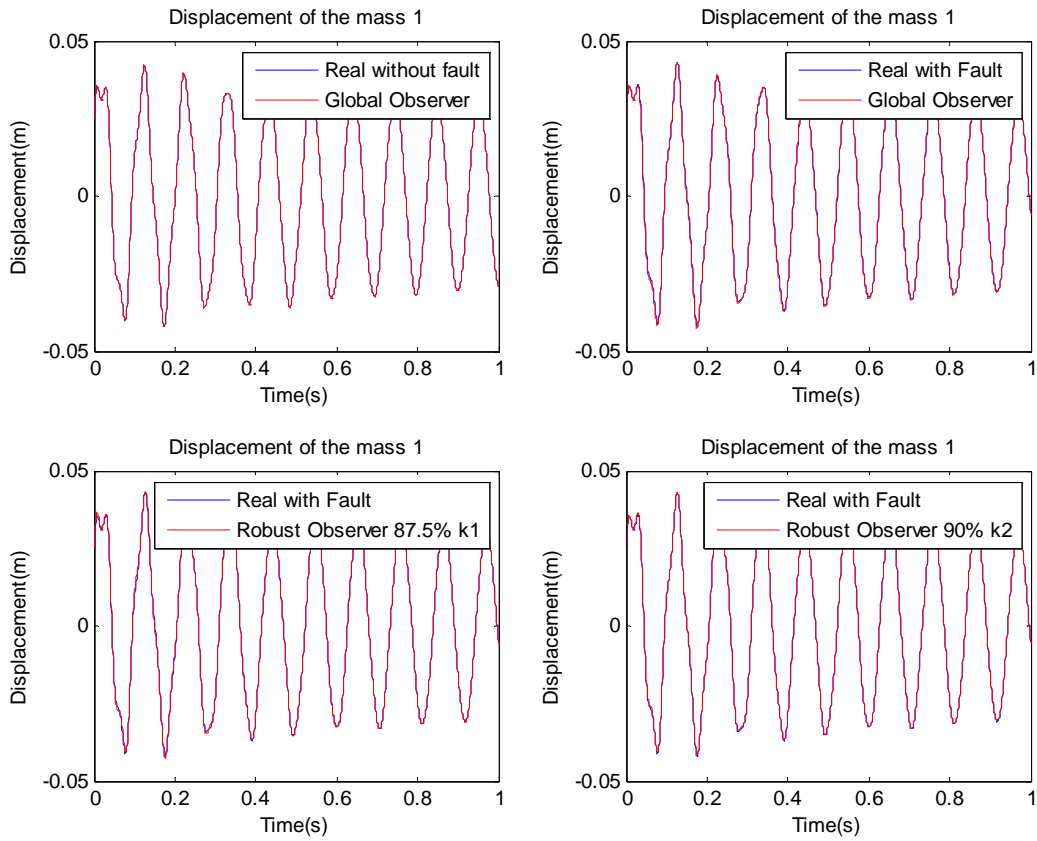

Figure 6 – Displacement of mass 1 of the real system and of the state observer.

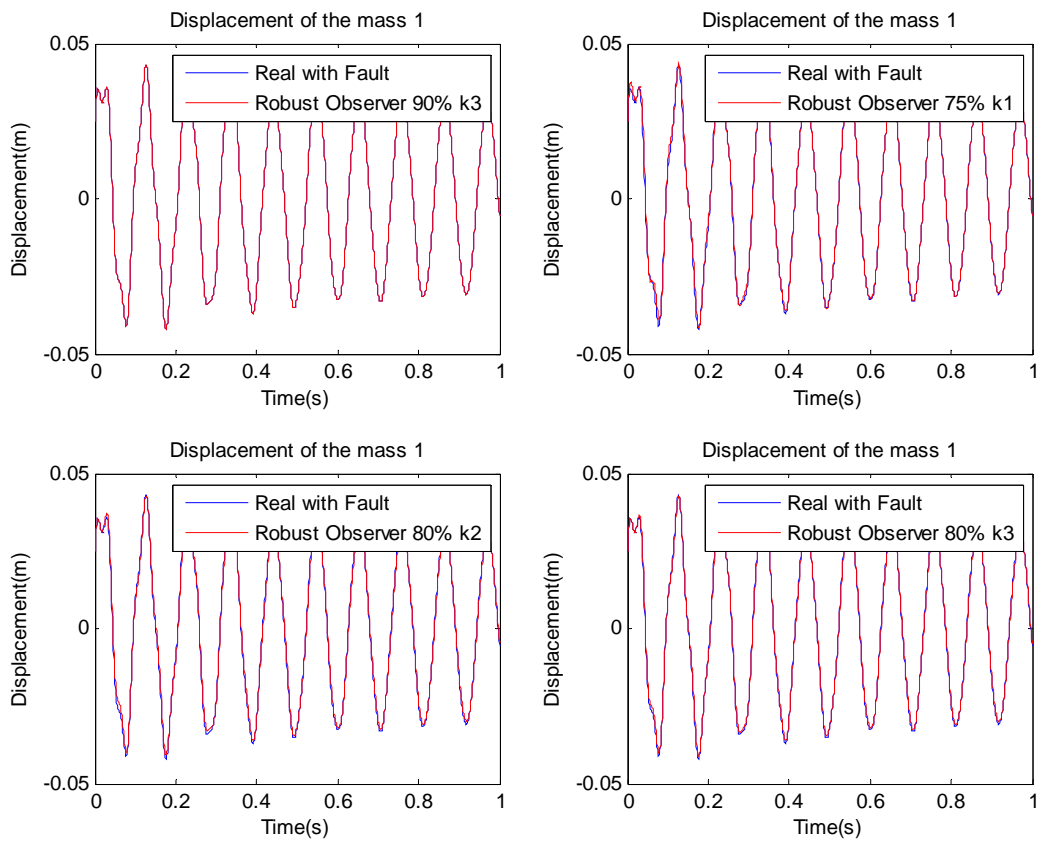

Figure 7 – Displacement of mass 1 of the real system and of the state observer.



Table 3 presents the difference of RMS values of the curves displacement of the real system with and without imperfection and of the global robust observers and of the specific parameters.

Table 3 – RMS difference between real system and state observer

Bank of State Observers	Real System without Fault	Real System with Fault
Global Observer	6.5138e-018	2.4026e-005
Robust Ob. 87,5% $k_1$	2.7837e-005	2.0133e-005
Robust Ob. 90% $k_2$	4.0963e-005	1.1349e-005
Robust Ob. 90% $k_3$	2.9354e-005	9.6919e-019
Robust Ob. 75% $k_1$	6.0520e-005	4.7222e-005
Robust Ob. 80% $k_2$	6.6381e-005	4.4610e-005
Robust Ob. 80% $k_3$	6.3372e-005	3.5410e-005

Analyzing the results of Table 2, the validity of the method is observed as the RMS difference between  $x_1$  real system without fault and  $x_1$  of the global observer was extremely small, demonstrating the validity of the result for the global observer. While that for the system with fault, it is observed that the smallest difference of RMS values occurred for the robust observer 90%  $k_3$ . Thus the fault in the system was determined, since a loss of 90%  $k_3$  was considered in order to simulate the fault in the system.

## 5 – CONCLUSIONS

From the results obtained, one can see the influence of the decay rate in the design of state observers by LMI. It was thought that the best results would be obtained with a higher decay rate, but the results showed that when a higher decay rate was used, an ill-conditioned state observer was obtained. Therefore, a methodology was developed to obtain a well-conditioned state observer by LMI. This methodology used the decay rate and the performance index. The first was used to improve the estimation time, and the second one was used to analyze the conditioned state observer.

With the well-conditioned state observers obtained, a methodology for fault detection could be developed. The technique of fault detection using state observers consists in the capacity of state observer to reconstruct the states not measured or values proceeding from points of difficult access in the system. The need to choose the parameters subject to fault or their percentile loses for the robust observer project was verified.

There is a restriction in the developed methodology that is the system should be observable with the number of measurements carried out. If this does not occur, other measurements must be conducted until the system becomes observable. A system considered was a three degree-of-

freedom mass-spring-damper system. Damage of 10% in one of the stiffness elements was detected, validating the methodology developed. This methodology was used in continuous systems, it was applied in real systems with good results and they will be presented in future. The only difficulty to use this technique is the observed and the representative mathematical model of the system.

## ACKNOWLEDGMENTS

The authors acknowledge the financial support of INCT-EIE, CNPq, FAPEMIG and FAPESP.

## REFERENCES

- ABBASZADEH, M., MARQUEZ, H. J. “LMI optimization approach to robust  $H_\infty$  observer design and static output feedback stabilization for discrete-time nonlinear uncertain systems”, **International Journal of Robust and Nonlinear Control**, p. 135-144, 2008.
- ABDALLA, M. O., ZIMMERMAN, D. C., GRIGORIADIS, K. M. “Structural Damage Detection using Strain Data via Linear Matrix Inequality Based Methods”, **American Control Conference**, San Diego, California, p. 1114-1118, 1999.
- ABDALLA, M. O., ZIMMERMAN, D. C., GRIGORIADIS, K. M., “Reduce Optimal Parameter Update in Structural Systems Using LMI”, **American Control Conference**, Chicago, Illinois, p. 991-995, 2000.
- ASSUNÇÃO, E. “Redução  $H_2$  e  $H_\infty$  de Modelos através de Desigualdades Matriciais Lineares: Otimização Local e Global”, **Tese (Doutorado)**, UNICAMP, Campinas, SP, 2000.
- BARA, G. I., DAAFOUZ, J., KRATZ, F., RAGOT, J. “Parameter-Dependent State Observer Design for Affine LPV Systems”, **International Journal of Control**, v. 74, n. 16, p. 1601-1611, 2001.
- BOYD, S., BALAKRISHNAN, V., FERON, E., EL GHAOU, L. “Linear Matrix Inequalities in Systems and Control Theory”, **Siam Studies in Applied Mathematics**, USA, 1994, 193 p.
- CHOY, F. K., LIANG, R., XU, P. “Fault Identification of Beams on Elastic Foundation”, **Computers and Geotechnics**, v. 17, p. 157-176, 1995.
- CLARK, R. N. “Instrument fault detection”, **IEEE Transactions on Aerospace and Electronic Systems**, Vol. AES-14, n. 3, p.456-465, 1978.
- D’AZZO, J. J., HOUPIS, C. H. “**Linear Control System Analysis and Design**”, São Paulo, McGraw-Hill, Inc, 1988, 660 p.
- ELMAS, C., DE LA PARRA, H. Z. “Application of a full-order extended Luenberger Observer for a position sensorless operation of a switched reluctance motor drive”, **IEE Proceedings Control Theory and Applications**, v. 143, n. 5, p.401-480, 1996.
- FAITAKIS, Y. E., TTHAPLIYAL, S., KANTOR, J. C. “An LMI Approach to the Evaluation of Alarm Thresholds”, **International Journal of Robust and Nonlinear Control**, v. 8, ed. 8, p. 659-667, 1998.

- FERNANDES, F. V., KOROISHI, E. K., MELO, G. P. "Diagnosis of Fault Using State Observers in with Dynamic Vibrations Absorbers". In: **Proceedings of 19th International Congress of Mechanical Engineering**, Brasília, DF, 2007.
- FRANK, P. M., SELIGER, R. "Fault Detection and Isolation in Automatic Processes", **Control and Dynamics Systems**, v. 49, p. 241-287, 1991.
- GE, W., FANG, C. Z. "Detection of faulty components via robust observation", Department of Automation, Tsinghua University, Beijing, China, p. 582-599, 1987.
- GHAOUI, L., NICULESCU, S. "Advances in Linear Matrix Inequalities Methods in Control", **Advances in design and Control**, Siam, EUA, 2000.
- HUH, K., STEIN, J. L. "A Quantitative Performance Index for Observer-Based Monitoring Systems", **Journal of Dynamic Systems, Measurement and Control**, v. 117, p. 592-599, 1994.
- HUH, K., STEIN, J. L. "Well-Conditioned Observer Design for Observer-Based Monitoring System", **Transactions of the ASME**, v. 117, p. 592-599, 1995.
- HUH, K., JUNG, J., STEIN, J. L. "Discrete-Time Well-Conditioned State Observer Design and Evaluation", **Journal of Dynamic Systems, Measurement, and Control**, v. 123, p. 615-622, 2001.
- HUH, K., JUNG, J., HONG, D. "A performance index for input observer-based monitoring systems", **American Control Conference**, v. 5, p. 4397-4402, 2003.
- JIANG, P., LI, C. "Observer-based robust stabilization for uncertain systems with unknown time-varying delay", **Journal of Control Theory and Applications**, v. 2, n. 2, p. 155-160, 2004.
- JIANG, G. P., TANG, W. K. S. "A State-Observer-Based Approach for Synchronization in Complex Dynamical Networks", **IEEE Transactions on Circuits and Systems I: Fundamental Theory and Applications**, v. 53, ed. 12, p. 2739 – 2745, 2006.
- LEMOES, G. F., MELO, G. P. "Fault Detection of Rotor-Support Structure Including Foundation Effects Using Reduced Order State Observer", **XXIV Iberian Latin-American Congress on Computational Methods in Engineering**, Universidade Federal de Ouro Preto, Ouro Preto, MG, Brasil, 2003.
- LEMOES, G. F., MELO, G. P. "Fault Diagnosis in Rotation System Using well Conditioned State Observer", **IMAC XXII-A Conference on Structural Dynamics**, Dearborn, Michigan, USA, 2004.
- LUENBERGER, D. G. "Observing the State of a Linear System", **IEEE Military Electronics**, v. MIL-8, p. 74-80, 1964.
- LUENBERGER, D. G. "Observers for Multivariable Systems", **IEEE Transactions on Automatic Control**, v. AC11, p. 190-197, 1966.
- LUENBERGER, D. G. "An Introduction to Observers", **IEEE Transactions on Automatic Control**, v. AC16, n. 6, p. 596-602, 1971.
- MOHIUDDIN, M. A., KHULIEF, Y. A. "Coupled Bending Torsional Vibration of Rotors Using Finite Element", **Journal of Sound and Vibration**, v. 223, n. 2, p. 297-316, 1999.
- MORAIS, T. S., KOROISHI, E. H., DANIEL, G. B., MELO, G. P. "Utilização do Filtro de Kalman para Detecção de Falhas em Sistemas Mecânicos Considerando Ruídos e entradas Não Lineares", **Anais do XXVI Iberian Latin American Congress Computational Methods Engineering**, Guarapari, ES, 2005.
- PALHARES, R. M. "Filtragem Robusta: Uma Abordagem por Desigualdades Matriciais Lineares", **Tese de Doutorado**, UNICAMP, Campinas, SP, 1998.
- PARK, J. K., SHIN, D. R., CHUNG, T. M. "Dynamic observers for linear time-invariant systems", **Automatica**, p.1-5, 2001.
- PARK, J. H., JUNG, H. Y., PARK, C. H. "Design of State Estimator for Discrete-Time Neural Networks: Delay-Independent Approach", **Journal of the Physical Society of Japan**, p. 24-32, 2008.
- SILVA, S., LOPES JR., V., Assunção, E. "Robust Control to Parametric Uncertainties in Smart Structures Using Linear Matrix Inequalities", **Journal of the Brazilian Society of Mechanical Science and Engineering**, v. XXVI, n. 4, p. 430-437, 2004.
- TEIXEIRA, M. C. M., PIETROBOM, H. C., ASSUNÇÃO, E. "Novos Resultados sobre a Estabilidade e Controle de Sistemas Não-Lineares Utilizando Modelos Fuzzy e LMI", **Controle & Automação**, v. 11, n. 1, p. 37-48, 2000.
- TEIXEIRA, M. C. M., LORDELO, A. D. S., ASSUNÇÃO, E. "On LMI Based of SPR Systems and Output Variable Structure Controllers", **6th International Workshop on Variable Structure Systems (VSS'2000)**, Coolangatta Gold Coast, Australia, 2000, p. 199-208.
- TRINH, H., ALDEEN, M. "A reduced-order state observer for large-scale discrete-time systems", **Pergamon, Computers Electric. Engng**, p. 301-309, 1998.
- VALER, C. E. I. "Uma Introdução ao Controle Robusto com Aplicações a Estruturas Flexíveis", **Dissertação (Mestrado)**, PUC, RJ – Depto. de Engenharia Mecânica, 1999.
- VAN ANTWERP, J. G., BRAATZ, R. D. "A Tutorial on Linear and Bilinear Matrix Inequalities", **Journal of Process Control**, v. 10, p. 363-385, 2000.
- WANG, H. B., WANG, J. L., LAM, J. "Robust Fault Detection Observer Design: Iterative LMI Approaches", **Journal of Dynamic Systems, Measurement, and Control**, v. 129, ed. 1, p. 77-82, 2007.
- WATANABE, K., HIMMELBLAU D. M. "Instrument Fault Detection in Systems with Uncertainties", **International Journal of Systems Science**, v. 13, n. 2, p. 137-158, 1982.
- YAZ, E. E., JEONG, J. S., YAZ, Y. I. "An LMI approach to discrete-time observer design with stochastic resilience", **Journal of Computational and Applied Mathematics**, v. 188, ed. 2, p. 246-255, 2006.